

ZF 314 Fixed Infrared Sensors Operating Instructions

Small and robust infrared temperature sensor

- ☆ 2-wire installation
- ☆ Linear current output
- ☆ Easy installation and connection

Specifications :

Spectral range : 8 ~14 μm
 Distance:Spot Size = 20 : 1 (measuring distance / spot size)
 Output Temperature range: 0°C ~400°C(0.04mA/°C)/ 32°F~752°F(0.022mA/°F)
 Analog output: 4~20mA ; linear to temperature
 Loop impedance: Max. 700 Ohms@24VDC; Min. 100 Ohms recommended
 Max. 150 Ohms@12VDC; Min. 100 Ohms recommended

Emissivity: Fixed at 0.95
 Response time: 0.3s
 Accuracy: 2.0% of temperature reading or 2.0°C/3.6 °F, whichever is greater
 Repeatability: 1% of measured value or 1°C/ 1.8°F , whichever is greater
 Warm up time: 10 minutes
 Connection cable: 1 m length, PVC
 Power supply: Isolated Power 12VDC~24VDC@20 mA, Ripple< 2.5%
 Ambient temperature: 0°C ~ 70°C /32°F ~158°F
 Storage temperature:- 30°C ~ 85°C/-22°F ~185°F
 Housing: Stainless Steel Tube
 Mounting Nut : M22
 Dimensions/ Weight: L= 110 mm x Φ =22 mm / 164 g
 Enclosure rating: IP65 (according DIN 40 050)
 Vibration: IEC68-2-27 (MIL STD 810D), any axis, 11 to 200 Hz, 3G
 Shock: IEC68-2-27 (MIL STD 810D), any axis, 11 ms, 50G

Current Loop Output & Target Temperature:

The following table shows the relationship for the Current Loop Output with the Target Temperature. The different Current Loop Output is corresponding to the relevant target temperature.

Table 1: Current Loop Output & Target Temperature

Code	Current Loop Output [mA]	Target Temp [°C /°F]
1	4.00	0.0°C/ 32°F
2	8.00	100°C/ 212°F
3	12.00	200°C/ 392°F
4	16.00	300°C/ 572°F
5	20.00	400°C/ 752°F

Installation Instruction:

The installation process contains two parts:

1. Bracket installation
2. Sensor parts assembly

Step 1:

Fixed Mounting Bracket

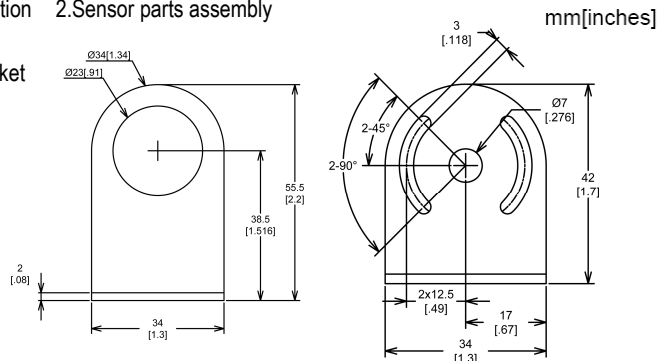

Figure 1:
The Fixed Mounting Bracket

Step 2: Adjustable Mounting Bracket

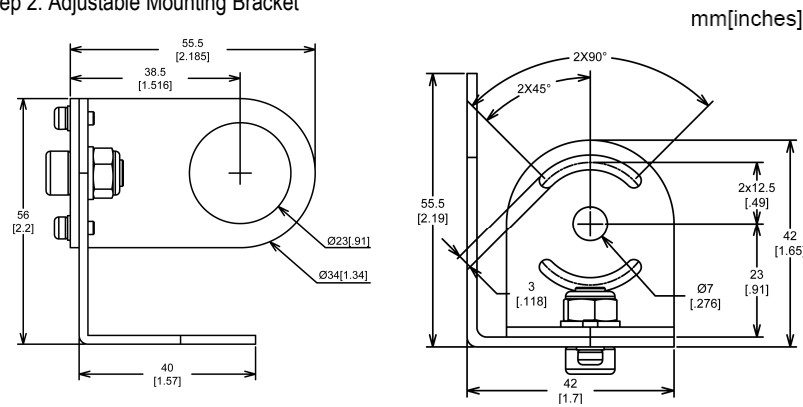

Figure 2: The Adjustable Mounting Bracket

Step 3: The sensor parts assembly

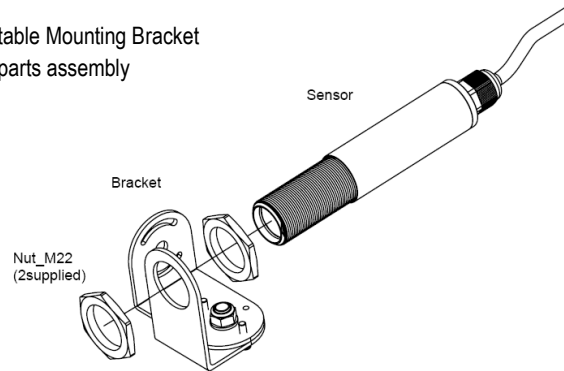

Figure 3: The Sensor Parts Assembly

Step 4: Accessories Installation

The working environment is with dust, smoke will dirty up the optical lens, and will influence the temperature readings, In order to keep the surface of the optical lens clean, the option accessory of air purge collar is recommend, see fig 4 (Air Purge accessories and option), Please refer to the following pictures:

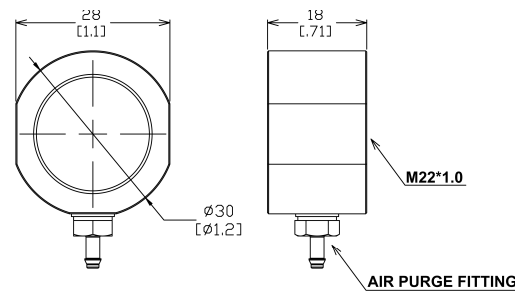

Figure 4: Air Purge accessories and option

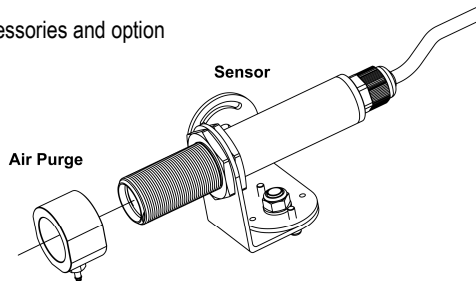

Figure 5: Air Purge Assembly

FOV & Dimension & Power Inlet instruction:

● FOV (Field Of View)

This diagram shows the measurement range of the sensor. The Distance: Spot Size is 20:1. The Spot Size should not be larger than the target if you wish to measure the temperature. You can choose the any target based on your optional under this principle.

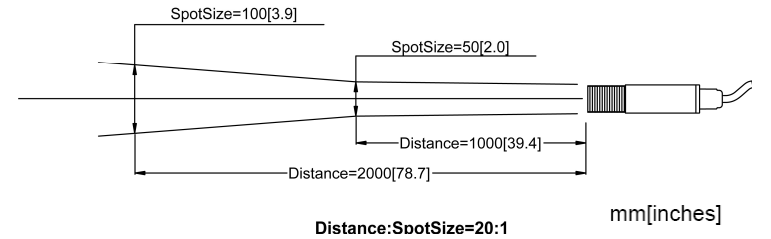

Figure 6: The FOV indication

● Dimension

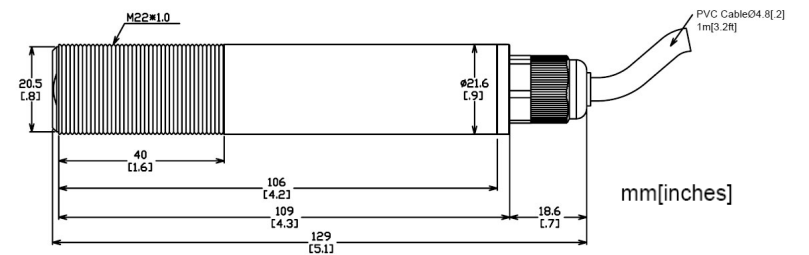

Figure 7: The Detailed Dimension

● Wire connection

The following diagram and table show the proper wiring connections. Each wire is numbered with the number and the relative color. Please follow the function guide when you connect the wire.

Warning: Please pay the special attention to the wire connection for the Green (V+) and Brown (V-). Please take care that Shield Line can not be linked with any Power line (Green (V+), Brown (V-)), and the shield wire is connecting to earth grounded at one point. The false wire connection will directly lead to the irreparable damage to the Fixed Infrared Sensors.

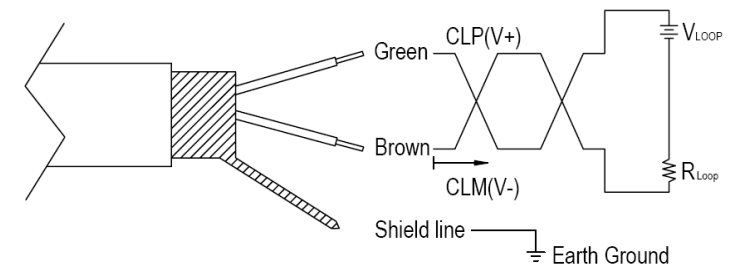

Figure 8: Wiring Configuration

Table 2: Wire Color & Connection Indication

Wire No	Wire Color	Label	Function
1	Green	CLP	Current Loop plus(V+)
2	Brown	CLM	Current Loop minus(V-)
3	Bare	-	Shield Ground

(Specifications are subject to change without notice.)



Ref.No. : 022011